

Living up to Life

Leica
MICROSYSTEMS

MEDICAL DIVISION



Leica M822

The Ultimate Red Reflex Ophthalmic Surgical Microscope



Leica M822: Legendary Leica, Visionary Technology

The Leica M822 ophthalmic surgical microscope features a dual illumination system with an LED for the main light and halogen for unsurpassed and stable red reflex. This innovative illumination system, combined with world class Leica optics, provides surgeons with unprecedented vision to perform surgery more precisely and efficiently.

› Optics and illumination

Precision Leica optics paired with a dual LED and halogen illumination system for a brilliant, stable red reflex

› Ergonomic design and easy use

Excellent vision, comfortable posture for the surgeon, and intuitive control for efficient workflow and precision microsurgery

› Total image management

High-definition video for display, documentation, and communication of procedures and cases

› Flexibility with long term value

OpenArchitecture™ to best handle a variety of surgical procedures, use of special accessories, and adapt to future needs



Optics and Illumination

Razor-sharp, high-resolution imaging with brilliant, stable red reflex

The unique combination of halogen and LED delivers bright, three-dimensional illumination and excellent red reflex. This innovation, paired with outstanding Leica optics, gives surgeons unprecedented vision to perform both cataract and retinal surgeries.

LEICA OPTICS

Images with natural color, superior depth of field, and high contrast deliver crucial information for successful ophthalmic surgery. The Leica M822 incorporates proven 800-series APO OptiChrome™ optics for high resolution of the smallest details.

LEICA LOW LIGHT CONCEPT

The extraordinary degree of light transmission and the high efficiency of the coaxial OttoFlex™ provide the surgeon with a bright, highly defined image, even at low light levels. The benefits for patient and surgeon are many: a more natural image for greater viewing comfort, reduced corneal glare, and greater efficiency – which can translate into better surgical outcomes.

BRILLIANT, STABLE RED REFLEX

With coaxial OttoFlex™ technology, the Leica M822 provides unsurpassed red reflex. Even the smallest cortical fragments can be clearly seen with minimal light. The large coaxial OttoFlex™ diameter provides stable red reflex throughout all steps of cataract surgery. Even if the eye moves intra-operatively during phaco, it remains in the field of illumination.

The Leica M822 builds on the success of the Leica M800 family, and includes a series of refinements and new features to give surgeons even more viewing comfort and flexibility.





Total cost of microscope ownership (general illustration)

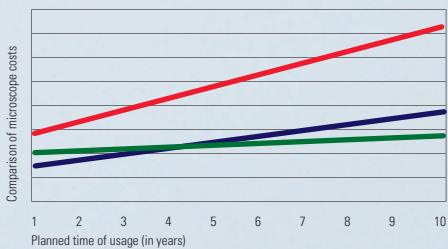

- Leica M822 F20 / F40 / C40 / CT40 with LED and direct halogen
- Other microscopes with halogen only and fiber optic cable
- Other microscopes with xenon and fiber optic cable

Comparison is based on initial purchase price, average consumption of bulbs and periodic fiber optic cable replacement costs.

Start saving from day one with the Leica M822 F20 / F40.

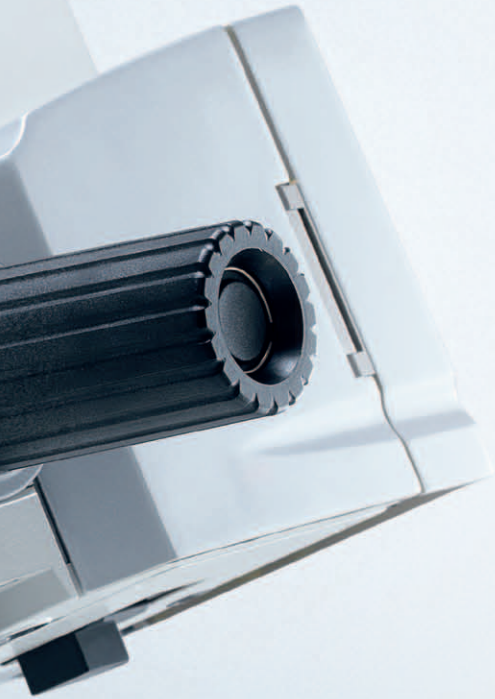

LED ILLUMINATION – RELIABLE, SAFER, ECO-FRIENDLY, AND ECONOMICAL

THE DEPENDABLE CHOICE

An LED light source in a surgical microscope offers significant advantages over xenon and halogen sources. The nominal service life of an LED is up to 60,000 hours. In comparison, xenon and halogen lamps, but also fiber optic cables, need to be changed frequently. The reduced service requirement means fewer interruptions during surgery, more uptime, and smoother workflow.

CAREFULLY ENGINEERED

Leica Microsystems first introduced LED technology into ophthalmic surgical microscopes in 2008. With continued development and refinements, the Leica M822 microscope features the newest LED technology, which offers halogen-like light for a natural color rendering.

SAFER SURGERY

The Leica M822 microscope combines high transmission optics with a dual illumination system consisting of LED plus halogen. The result: a surgeon is free to adjust the optimum light balance, at the lowest possible light intensity, to achieve the best results in terms of red reflex, contrast, and recognition of important details.

ECO-FRIENDLY TECHNOLOGY

As efficient lighting technology, such as LED, become more of the norm, they are changing the energy paradigm. LED light has a lower energy consumption, longer lifespan, and greater durability and reliability than other sources. These characteristics, combined with Leica's Low Light Concept, result in an environmentally-friendly microscope.

COST EFFECTIVE

LED illumination adds value by reducing operating costs throughout the life of the microscope. But the real savings is this: fewer lamp changes mean fewer disruptions and less downtime, which enhances efficiency.



Ergonomic Design and Easy Use

See better, work better, feel better

Working in comfort allows the surgeon to have full concentration. The Leica M822 is designed to not only give surgeons the best possible view, but also help them to feel better while working, day in and day out. Natural posture and fluid movement can mean less tension, less fatigue, and better work.

THE INTUITIVE MICROSCOPE

The controls, adjustments, and movements of the Leica M822 are highly intuitive, making it comfortable to use. The controls and interfaces are designed for easy use, logical workflow, and personal preferences. At the microscope, absorbed in concentration, a surgeon can focus on the patient and surgery, not on the microscope settings.

FOR YOUR EYES ONLY

ErgonOptics™ is Leica's broad range of interchangeable binoculars and lens types to meet the individual vision requirements of each user. No other microscope system offers such a wide range of lenses and binoculars for surgeons and assistants. The unique UltraLow™ III binocular for example moves lower than other binoculars to allow stacking of auxiliary accessories.

see better
work better
feel better



VARIETY OF FLOOR STANDS AND CEILING MOUNTS ^[1]

The microscope is very convenient to position and move in the operating room. Leica offers floor stands and two space-saving ceiling mounts for the Leica M822, so the optimal setup can be selected for any OR. Whether on a stand or ceiling mount, the swingarm provides long reach and quickly adjusts into position, locking in for a rock-steady view.

AUTO RESET FOR THE NEXT OPERATION ^[2]

When the surgeon pushes the swingarm up and away from the operating table after each procedure, all microscope functions automatically reset. Now the microscope is ready for the next operation. The staff does not need to reset the system beforehand, which saves time and provides peace of mind for staff and the surgeon.

TEMPORAL APPROACH CATARACT SURGERY ^[3]

The Leica Rotatable Beamsplitter is the world's first two-beampath solution for temporal approach cataract surgery. The easy, side-to-side quick change of the optics for the assistant observer saves time between cases and increases efficiency in the operating room.

Operating table and chair shown courtesy of brumaba GmbH & Co. KG

Pre- and post-surgery



SIMPLE AND VERSATILE CONTROL ^[4]

The user-friendly touchscreen control unit offers intuitive control of all microscope functions. Up to 30 surgeons can set their individual preferences, so the microscope is always ready for each surgeon. With the touch of a button, the screen switches between microscope control display and real-time video monitor (two-in-one display).

MULTIFUNCTION CABLED AND WIRELESS FOOT SWITCHES ^[5]

To meet the needs of all users, four models of foot switches are available: cabled or wireless, 12-function or 16-function, which offers four additional freely programmable microscope or accessory functions. The Leica Wireless Footswitch offers maximum mobility for fast, easy adjustments.

PRESETS FOR REPETITIVE PROCEDURES ^[6]

StepCycle™ allows the surgeon to program and switch between predefined settings such as illumination, focus, and zoom for each step of a procedure. He or she can select these presets using the footswitch, which saves time and keeps the hands free for uninterrupted work.

During surgery



3



5



4

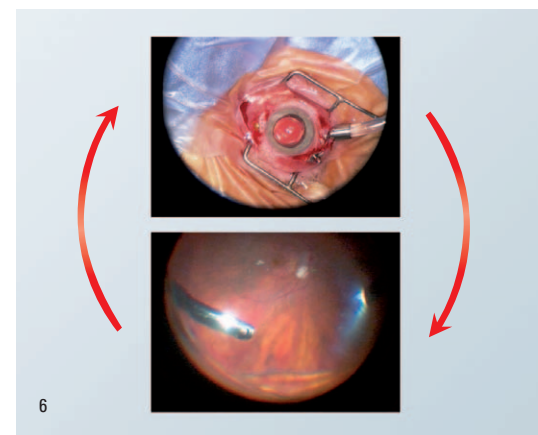

6



LEICA M822

LEICA F40

Total Image Management

High definition video for display, documentation, and communication

When the surgeon wants to share still images or videos with OR staff in real time, show a colleague an interesting case, document a procedure for referring physicians, and facilitate consultation with a family – HD and the use of mobile devices are now standard.

STANDARD AND / OR HIGH DEFINITION VIDEOS

The Leica M822 OpenArchitecture™ allows the capture of digital standard videos and still images with a variety of commercially available cameras and recording systems. With the optional Leica HD C100 high definition medical grade camera and the Med X Change video recording and documentation systems, surgical cases can now be recorded in best quality.

DOWNLOAD AND SHARE

The Med X Mobile® application uniquely facilitates wireless transfer of HD videos and still images from the microscope capture system to the Apple® iPhone®, iPod Touch®, or iPad® within seconds. With a USB cable, selected files can also be transferred to most Android™ devices. This allows cases to be transported, viewed, and discussed with colleagues or the patient's family immediately after surgery.

MODERN VIDEO TECHNOLOGY

The Leica M822 offers an ideal package for capturing and exchanging video information:

- › State-of-the-art HD recording system with MPEG4 video compression and picture-in-picture function
- › Leica HD C100 high definition medical grade camera with newest imaging technology
- › Selection of unique Leica video adapters for intra-operative fine focus of a video with manual or remote control, and integrated zoom function



› Apple, iPad, iPhone, and iPod Touch are trademarks of Apple Inc., registered in the U.S. and other countries.

› Android is a trademark of Google Inc.

› Med X Mobile and Med X Change are trademarks of Med X Change Inc., registered in the U.S. and other countries.



Flexibility with Long Term Value

Flexibility today and compatibility tomorrow add up to a smart long-term investment

The Leica M822 includes mechanical and electronic interfaces to accept and easily mount a wide range of accessories – now and into the future. These improve workflow, support better surgical outcomes, and allow new surgical techniques to be adopted.

LEICA RUV800 ^[1]

The Leica RUV800 is the solution for panoramic viewing in retinal surgery. The integrated inverter gives the surgeon, assistant, and video camera the same upright view of the retina. The Leica M822 also fully integrates the commonly used wide-angle observation systems or stereo image inverters, such as the OCULUS SDI / BIOM[®] ^[2].

LEICA DI C800 ^[4]

With the Leica DI C800 head-up display, images from digital sources, providing an XGA signal, can be projected directly into the surgeon's eyepiece. This cockpit-style display can show data precisely where the surgeon needs it.

LEICA SLIT ILLUMINATOR ^[3]

This intra-operative precision surgical slit lamp is ideal for anterior and posterior segment surgery. Using the Leica slit lamp, both of the surgeon's hands are free for the operation, which allows a more fluid procedure.

LEICA TORICEYEPIECE ^[5]

The Leica ToricEyePiece is a cost-effective, easy-to-use, time-saving aid for Toric IOL placement. The rotatable scale is superimposed over the microscope image to help the surgeon find the correct IOL positioning.

LEICA KERATOSCOPE ^[6]

The Leica Keratoscope is an integrated, cost-efficient aid to determine astigmatism in anterior segment surgery.

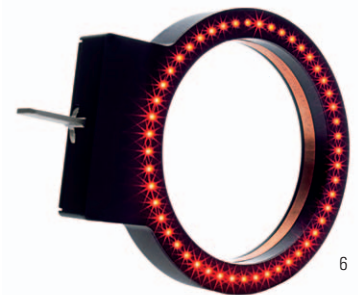

6

Using one microscope for cataract and vitreoretinal surgery is a very economical approach. It is easy to change the Leica M822 from one setup to the other.



5

¹ OCULUS and BIOM are trademarks of OCULUS Optik-geräte GmbH, registered in the U.S. and other countries.

Technical Specifications

The Leica M822 F20 / F40 / C40 / CT40 ophthalmic surgical microscopes feature precision Leica optics, a dual LED and halogen illumination system for brilliant red reflex and natural lighting, ergonomic design, intuitive control, total image management, and built-in flexibility to serve multiple uses and adapt to future needs.

ELECTRICAL DATA

Power supply F20 100–240 V, 50/60 Hz, 400 VA

Power supply F40 / C40 / CT40 100–240 V, 50/60 Hz, 300 VA

Safety class / Type Class 1

LEICA M822 MICROSCOPE

Magnification APO-Zoom 6:1, motorized, with 2 separate beam paths changer

Magnification 3.5x – 21x (WD 175 mm, 10x eyepieces)

Optics APO-chromatic corrected optics

Field diameter 7 mm – 80 mm

Working distance 175 mm, 200 mm, and 225 mm

Focus range 54 mm, motorized, with automatic reset

Eyepieces Widefield eyepieces for eyeglass wearers (8.33x, 10x, 12.5x)
Dioptic setting ± 5 with adjustable eye cup

Objective Leica OptiChrome™, WD 175 mm, APO
Leica OptiChrome™, WD 200 mm, APO
Leica OptiChrome™, WD 225 mm, APO
(WD = working distance)

ILLUMINATION

Main lamp LED

Coaxial OttoFlex™ Two halogen lamps 12 V / 50 W

Quick-change lamp mount With two 12 V / 50 W halogen lamps for coaxial OttoFlex™ lamp mount

LEICA F20 FLOOR STAND

Type Floor stand with 3 friction brakes

Balancing Continuously adjustable gas spring

Load Max. 11.5 kg accessories attached to the microscope

Reach Max. 1480 mm

Vertical range 650 mm

Transport height Min. 1940 mm

Weight Approx. 270 kg as a fully configured system

XY-unit Motorized, movement range 50 × 50 mm, with automatic reset

Tilt mechanism Motorized, +15° / –50°

Hand / foot switches 16- or 12-function foot switch with controls arranged longitudinally or transversally, wired or wireless
12-function hand switch

Control unit Two-in-one display: control and video display in one. The latest electronic control for the continuous governing of all motor functions and the light intensity. Data shown by means of LCD, with adjustable contrast and brightness. Operation by modern touch-panel control. ISUS™ Intelligent Setup System, menu selection based on unique software for user specific configuration, with built-in electronic auto-diagnosis and user support.

**LEICA F40 FLOOR STAND, LEICA C40 CEILING MOUNT,
LEICA CT40 TELESCOPE CEILING MOUNT**

Type	Floor stand with 4 electromagnetic brakes
Balancing	Continuously adjustable gas spring
Load	Max. 12.2 kg accessories attached to the microscope
Reach	Max. 1492 mm
Vertical range	846 mm
Transport height	Min. 1949 mm
Weight	Approx. 330 kg as a fully configured system
XY-unit	Motorized, movement range 50 × 50 mm, with automatic reset
Tilt mechanism	Motorized, +15° / -50°
Hand / foot switches	16- or 12-function foot switch with controls arranged longitudinally or transversally, wired or wireless 12-function hand switch
Control unit	Two-in-one display: control and video display in one. The latest electronic control for the continuous governing of all motor functions and the light intensity. Data shown by means of LCD, with adjustable contrast and brightness. Operation by modern touch-panel control. ISUS™ Intelligent Setup System, menu selection based on unique software for user specific configuration, with built-in electronic auto-diagnosis and user support.

ACCESSORIES

Assistant attachment	Stereo assistant attachment
Beamsplitter	50% / 50%, 70% / 30%, Leica Rotatable Beamsplitter
TV / Photo	Leica HD C100 high-definition medical grade camera Leica 2D video systems Leica MDRS4 digital recording system Leica Zoom Video Adapter (VA) f = 35 – 100 mm, Manual VA 55/70 mm, Remote VA 55/70 mm Photo/TV dual attachment: f = 60/85/107 mm for TV, f = 250/350 mm for 35 mm camera Photo tube f = 250/350 mm
Wide-angle observation	Leica RUV800 Interface for Oculus SDI / BIOM

Inverters (interface)	AVI, SDI, DIVSL, ROLS
Laser interface	Interface to fit various commercially available lasers, adapters available from laser suppliers
Slit lamp	Motorized travel ±23°, slit width 0.01 – 15 mm, length 3 – 15 mm, rotatable 180°, quick-lamp changer
Keratotomy	Leica Keratoscope with 50 LEDs
Imaging	Leica DI C800 high resolution true color digital imaging module for data display, 1024 × 768 pixel resolution
IOL Placement	Leica ToricEyePiece
Binocular tubes	Variable angle 0° – 180° Variable angle 30° – 150° Variable angle 10° – 50° UltraLow™ III Variable angle 10° – 50° Variable angle 5° – 25° Inclined angle 45°
Hand / foot switches	wired 16- or 12-function foot switch with controls arranged longitudinally or transversally wireless 16- or 12-function foot switch with controls arranged longitudinally or transversally (optional) 12-function hand switch
Asepsis	Sterilizable protective glass for the objective, sterilizable components for all drive knobs, commercially available drapes
Network (optional)	DICOM compatibility for both videos and still images, archiving to patient records with Leica MDRS4 / Med X Change HDMD®

HD IMAGING

For more information, please refer to your local Leica Microsystems Sales Representative.

STANDARDS

Council Directive 93/42/EEC on Medical Devices (MDD) and its amendments. Classification: Class I, in compliance with Annex IX, rule 1 and rule 12 of the directive. Medical Electrical Equipment, Part 1: General Requirements for Safety IEC 60601-1; EN 60601-1; UL60601-1; CAN/CSA-C22.2 NO. 601.1-M90. Electromagnetic compatibility IEC 60601-1-2; EN 60601-1-2. The Medical Division, within Leica Microsystems (Schweiz) AG, holds the management system certificates for the international standards ISO 9001, ISO 13485 and ISO 14001 relating to quality management, quality assurance and environmental management.



Leica M822 F20

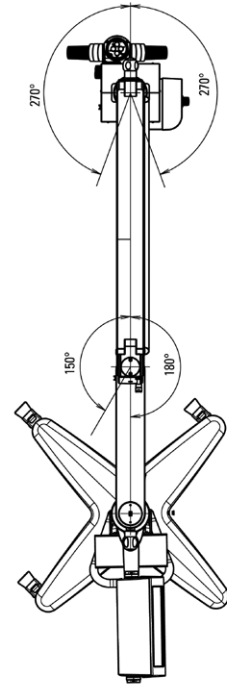
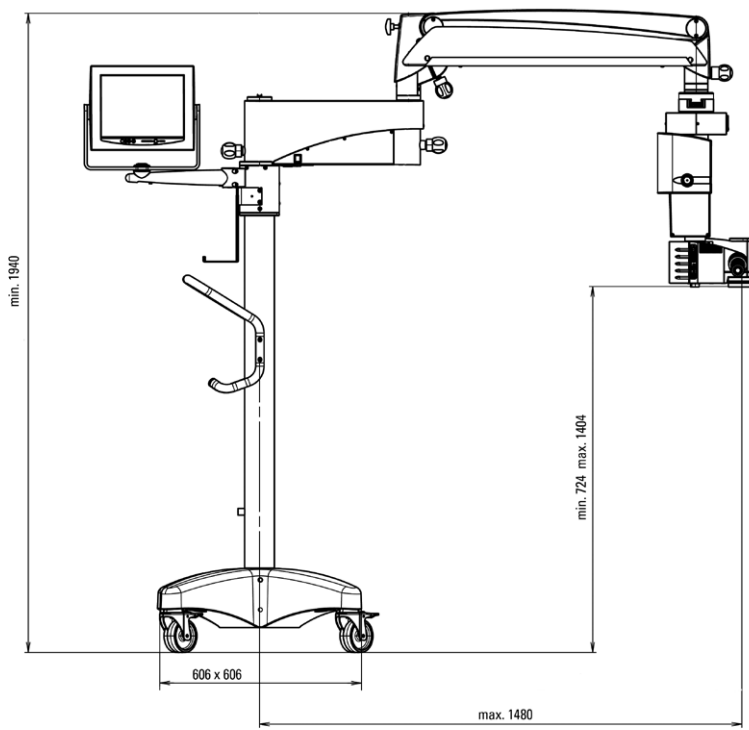

Leica M822 F40

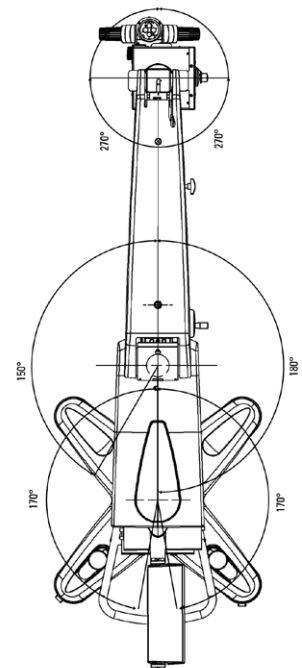
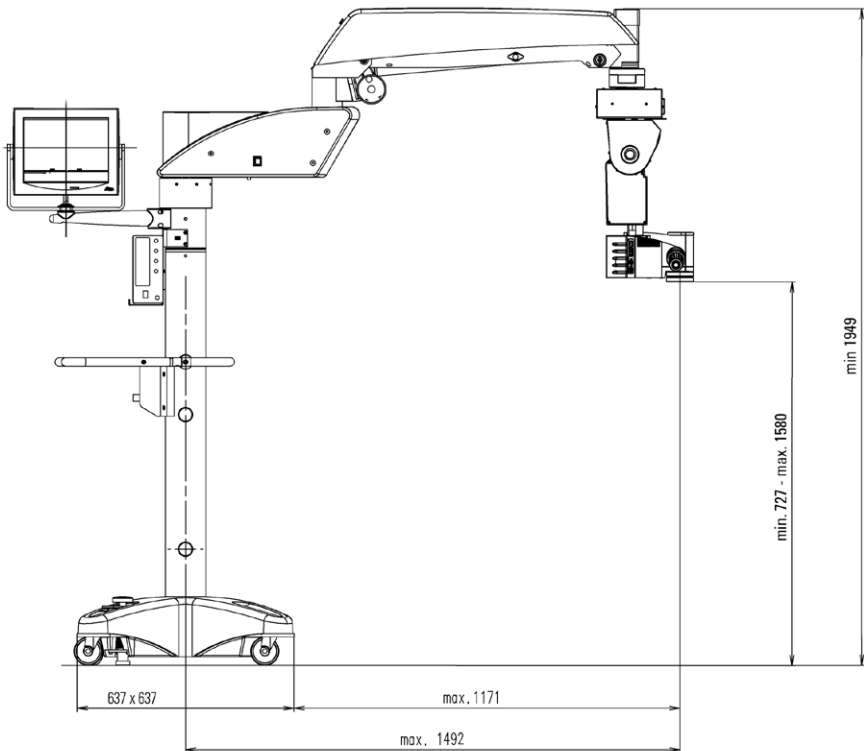

Leica M822 C40

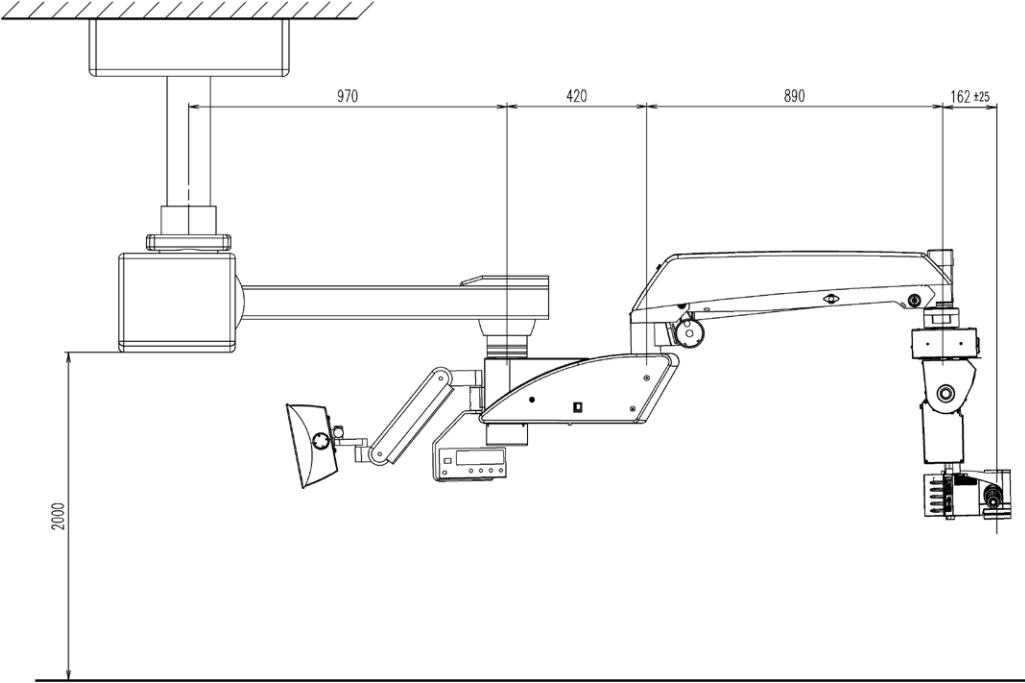

Leica M822 CT40

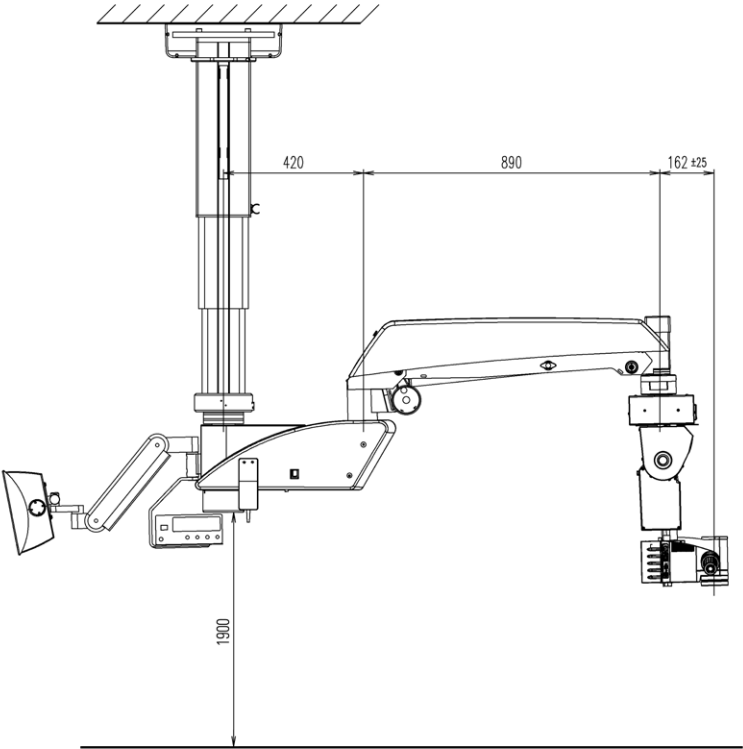



Leica M822 F20 floor stand with mechanical brakes ^[1]



Leica M822 F40 floor stand with electromagnetic brakes ^[2]



Leica M822 C40 ceiling mount ^[3]



Leica M822 CT40 telescope ceiling mount ^[4]

The fruitful collaboration “with the user, for the user” has always been the foundation of Leica Microsystems’ innovative strength. On this basis, we have developed our five corporate values: Pioneering, High-end Quality, Team Spirit, Dedication to Science, and Continuous Improvement.

Leica Microsystems – an international company with a strong network of worldwide customer services:

MEDICAL DIVISION

What does a surgeon expect from an outstanding surgical microscope? Sharp, clear images, and a modular system aligned with the surgeon and OR staff needs.

Innovations for your practice

From the first surgical microscope with widefield optics in the 1980s to the first microscopes with Horizontal Optics and with LED illumination, Leica Microsystems has been at the forefront of innovation in the development of surgical microscopes.

HD video, fluorescence and retinal viewing systems also demonstrate the continued innovative nature of the Leica team. We strive to provide the surgeon with leading edge technology to enhance performance, surgeon comfort, and patient outcomes.

Active worldwide	Tel.	Fax
USA · Buffalo Grove/Illinois	+1 800 248 0123	+1 847 405 0164
Canada · Concord/Ontario	+1 800 248 0123	+1 847 405 0164
Australia · North Ryde/NSW	+61 2 8870 3500	+61 2 9878 1055
Austria · Vienna	+43 1 486 80 50 0	+43 1 486 80 50 30
Belgium · Diegem	+32 2 790 98 50	+32 2 790 98 68
Denmark · Ballerup	+45 4454 0101	+45 4454 0111
France · Nanterre Cedex	+33 811 000 664	+33 1 56 05 23 23
Germany · Wetzlar	+49 64 41 29 40 00	+49 64 41 29 41 55
Italy · Milan	+39 02 574 861	+39 02 574 03392
Netherlands · Rijswijk	+31 70 4132 100	+31 70 4132 109
Portugal · Lisbon	+351 21 388 9112	+351 21 385 4668
Spain · Barcelona	+34 900 210 992	+34 93 494 95 40
Sweden · Kista	+46 8 625 45 45	+46 8 625 45 10
Switzerland · Heerbrugg	+41 71 726 34 34	+41 71 726 34 44
United Kingdom · Milton Keynes	+44 800 298 2344	+44 1908 246 312
China · Hong Kong	+852 2 564 6699	+852 2 564 4163
· Shanghai	+86 21 6387 6606	+86 21 6387 6698
Japan · Tokyo	+81 3 5421 2800	+81 3 5421 2896
Korea · Seoul	+82 2 514 65 43	+82 2 514 65 48
Singapore	+65 6779 7823	+65 6773 0628

